

# FRAMES

## INSTRUCTIONS FOR USE

Codes A Frame 44601, C Frame 44501, O Frame 44101



## SECTION

## PAGE START

1.0 A FRAME

3

2.0 C FRAME

15

3.0 O FRAME

26



# 1. A Frame

## INSTRUCTIONS FOR USE

Code 44601



CONTENTS	PAGE
1.0 INTRODUCTION	1
2.0 ILLUSTRATION & TECHNICAL DATA	2
3.0 FOR YOUR SAFETY	4
4.0 ASSEMBLING YOUR 'A' FRAME	5
5.0 CARE AND MAINTENENCE	8
6.0 WARRANTY AND SERVICE	11
7.0 CONTINUOUS IMPROVEMENT	11
8.0 SERVICE INSPECTION	12

---

## 1.0 INTRODUCTION

Thank you for choosing your new Smirthwaite 'A' Frame.

Our 'A' Frame is a free-standing suspension system for use with our sensory integration swing products. The frame eliminates the need for permanent structural fixings, is easy to transport and assemble. Made from tubular steel it will support rigorous activity and can be fixed to the floor if required.



### IMPORTANT!

**These instructions should be read by all therapists and carers using the equipment and should be retained for future reference. The product should always be used under adult supervision – this product is not a toy.**

**Any incorrect use of the product and failure to follow the instructions may put the user at risk or impede the function. If you have any queries using this product or wish for further copies, please do not hesitate to contact Customer Service department on T: +44 (0) 1626 835552.**

**This product has been designed and manufactured specifically and solely for use by clients with special needs.**



## 2.0 ILLUSTRATION OF YOUR 'A' FRAME

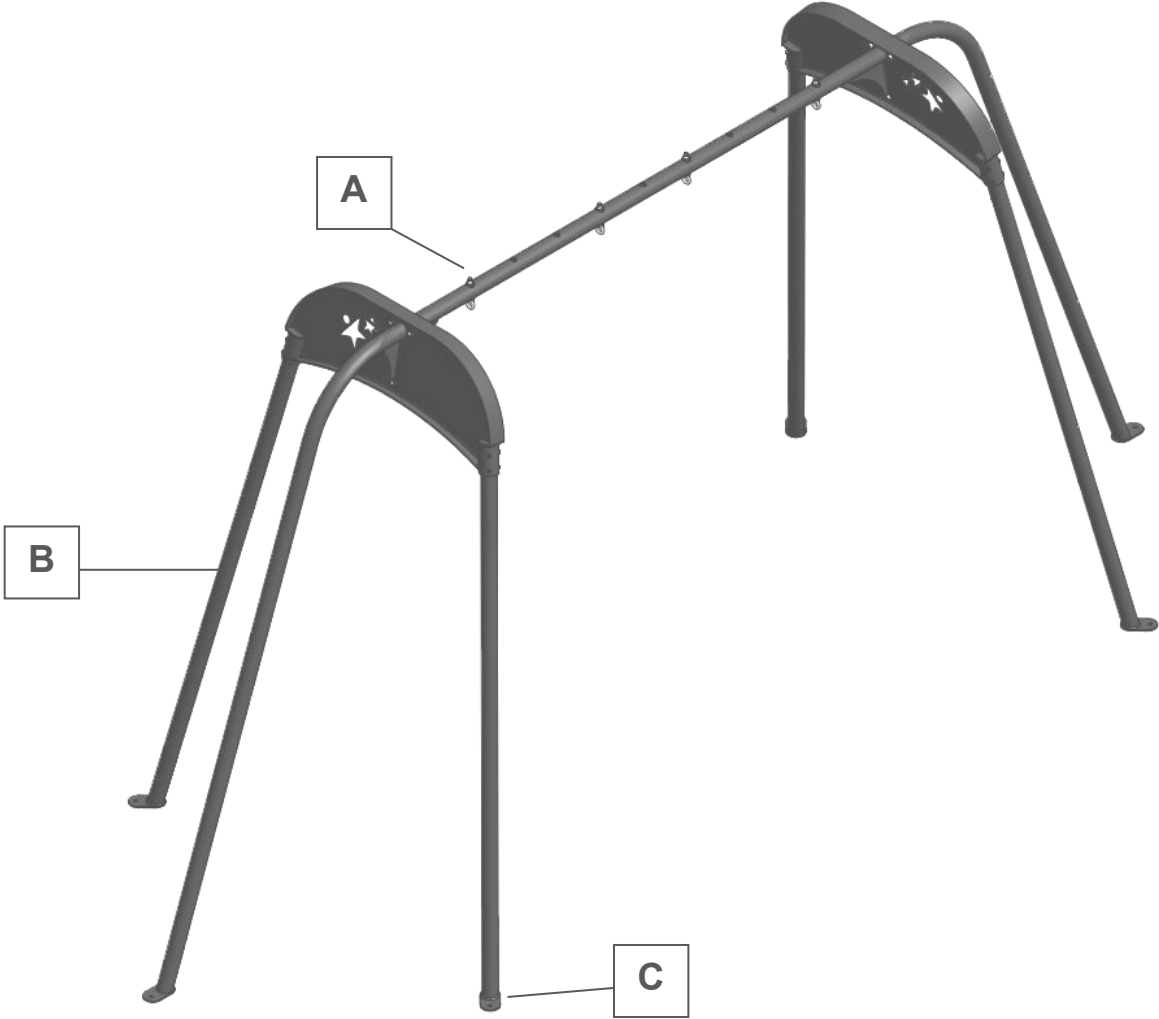

- A. Fixing points
- B. Vertical legs
- C. Fixing feet



## 2.1 TECHNICAL DATA

Size		1
Product Code		<b>44601</b>
Height	mm	2325
Length	mm	5181
Width	mm	1906
Maximum user weight	kg	300
Product weight	kg	120

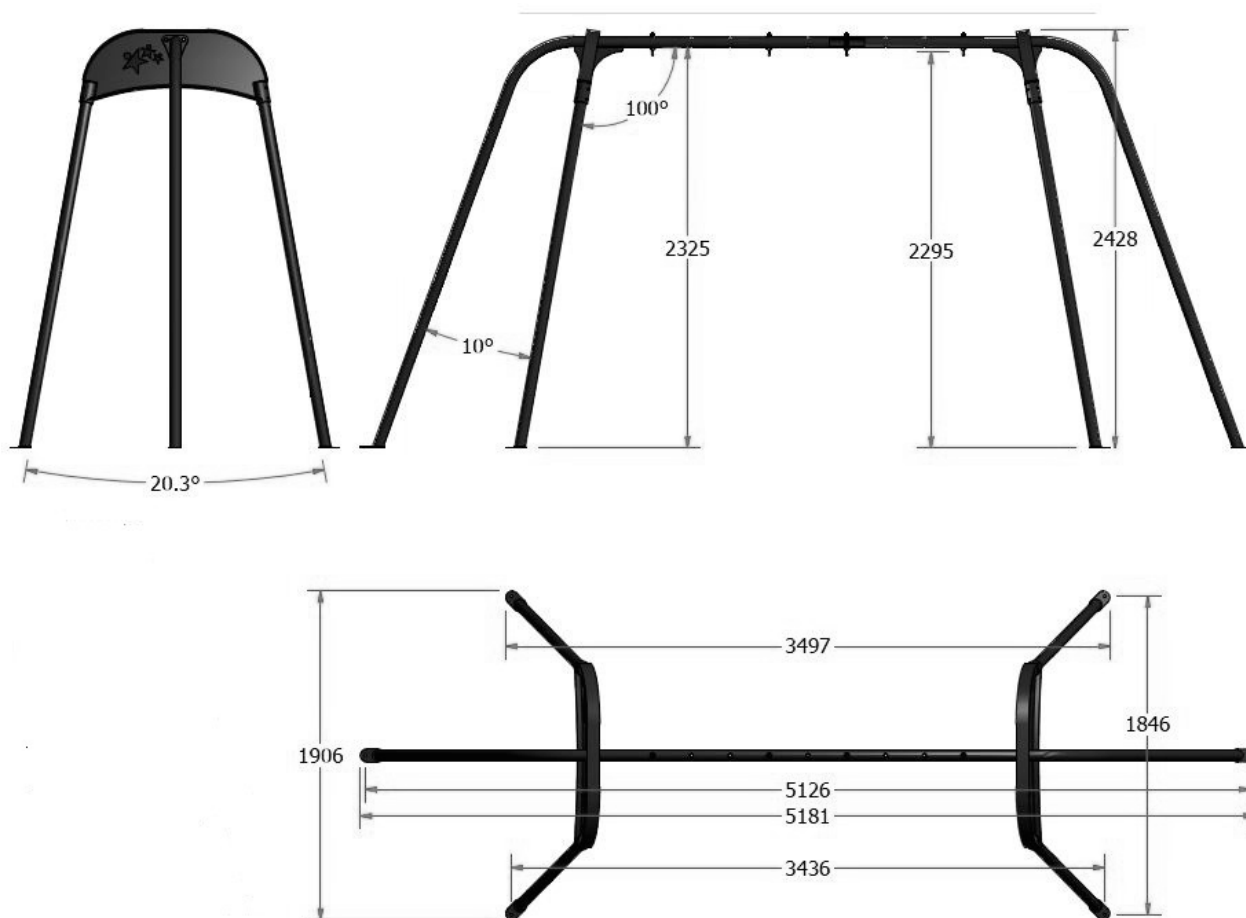

### 3.0 FOR YOUR SAFETY



**STOP!**

**Please read these instructions CAREFULLY and THOROUGHLY.**

- The user should NOT be left unattended whilst using the 'A' Frame. Always ensure a responsible adult or carer is in attendance – this product is not a toy.
- Regular maintenance checks and cleaning are essential for the safe use of this equipment (see care and maintenance section).
- Use only on a flat surface and do not exceed the weight limits specified.
- If any part is loose, damaged or functioning incorrectly, do not use until rectified.
- The 'A' Frame is supplied flat packed. Check before use that all parts are present and undamaged. Please refer to section 4.0 for assembly instructions.
- The 'A' Frame is supplied with basic protective padding on the exposed metal legs. The Frame may be supplied with this padding already fitted. To remove, it is possible to simply open the protective flap on each leg pad, and unzip.
- Padding should be periodically checked for damage and replaced when required.
- Padding can be cleaned with mild soap and warm water.
- An additional Mat Set is available for this frame – please Customer Service department on T: +44 (0)1626 835552 for further information, or to order.



**STOP!**

**If you believe this product to be faulty – DO NOT USE – Contact Smirthwaite Ltd on T: +44 (0) 1626 835552**



## 4.0 ASSEMBLING YOUR 'A' FRAME



### STOP!

If in any doubt, **ALWAYS** seek **ADVICE**.

Always turn screws clockwise to tighten or anti-clockwise to loosen.

**DUE TO THE WEIGHT AND SIZE OF THIS PRODUCT, WE ALWAYS RECOMMEND ASSEMBLY IS UNDERTAKEN BY A MINIMUM OF 3 PEOPLE.**

### 4.1 A FRAME – EXPLODED VIEW

- The A Frame is supplied in parts, consisting of:
  - 4 x upright vertical legs (D)
  - 2 x curved vertical legs (E)
  - 1 x horizontal span (F)
  - 2 x end plates (G)
  - 1 x fixing kit

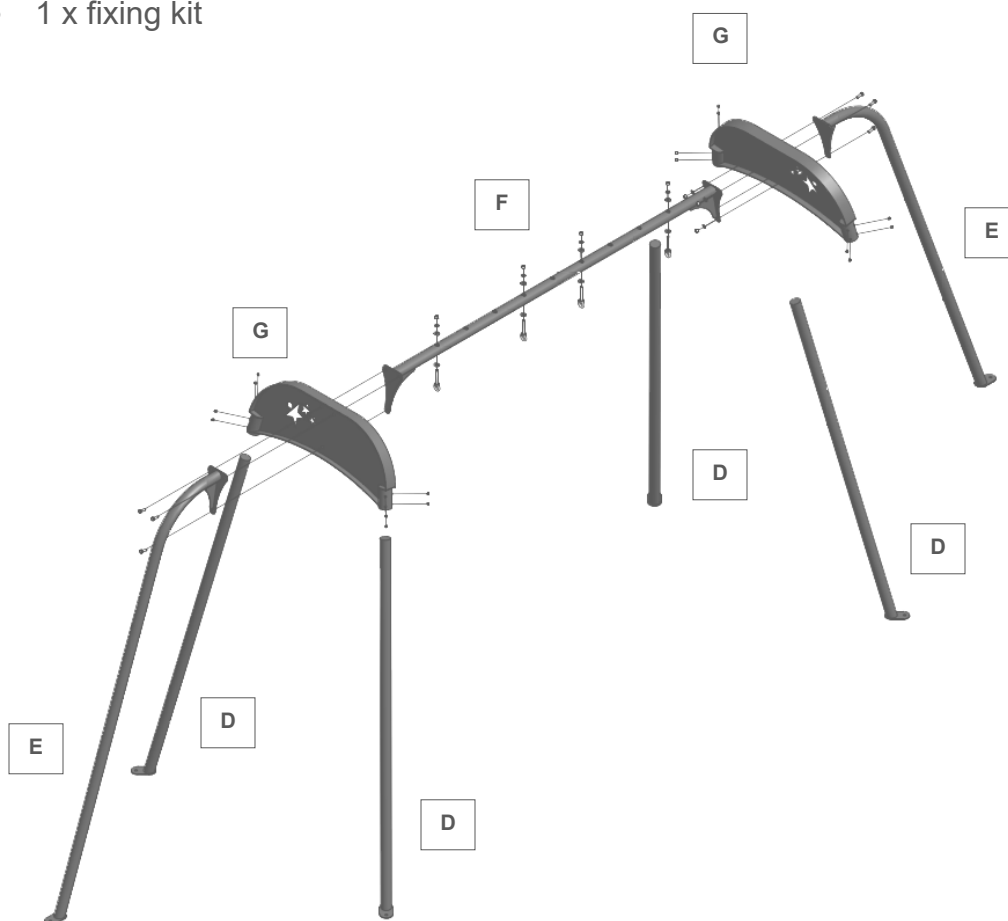



## 4.2 A FRAME – ASSEMBLY

- Insert and secure 2 x Upright vertical legs (D) into the sockets found in (G), as shown below.
- Offer up one curved vertical leg (E) and horizontal span (F). Support in place while securing together through (G) using M12 x 35 bolts (quantity 3), and 3 x M12 washers and nuts from the fixing pack. Ensure the assembly is secure.
- Repeat steps to assemble second end of frame.

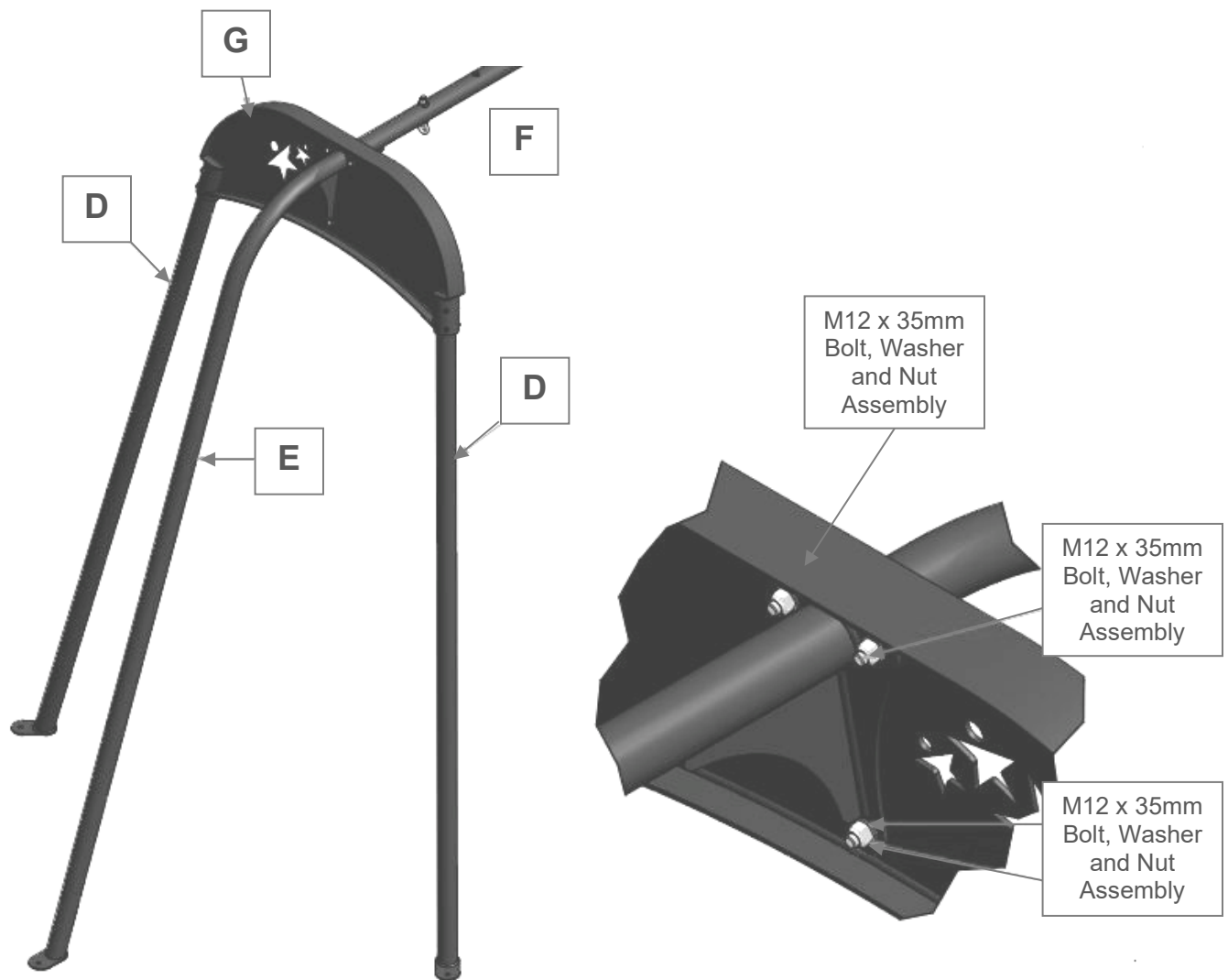

- Fit M12 Eyebolts to the horizontal span (F) as required. Ensure 2 x Saddle washers are fitted. Secure eyebolt in place with a M12 washer and nut as shown below.
- Ensure all fixings are tightened before using the 'A' frame.

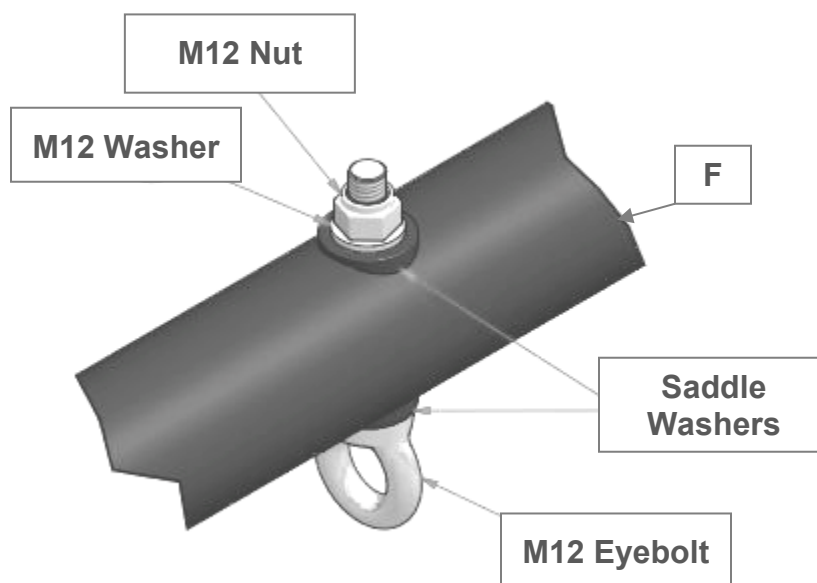

## 5.0 CARE AND MAINTENANCE



### IMPORTANT!

Cleaning is recommended on a regular basis

- The 'A' frame padding can be cleaned with a damp cloth and mild detergent.
- The 'A' frame can be stored/positioned indoors or out.
- For further information please refer to MHRA or NHS cleaning guidelines.

### 5.1 DAILY CHECKS

- Check the frame for damage or loose connection points
- Check all padding for signs of wear and tear
- If the 'A' Frame is installed fixed to the ground, ensure the feet and fixing points are secure
- Keep all parts clean.



### STOP!

DO NOT attempt to use the product while being checked or serviced.



## 5.2 SERVICE INTERVAL

The 'A' Frame should be serviced every year. Servicing must only be undertaken by a Smirthwaite service engineer, or by a Smirthwaite trained representative.

## 5.3 NOMINAL SERVICE LIFE

Your product has a nominal service life of 7 years, during which full post-sales support will be available with regard to spares and servicing.

Product service life has been determined based upon the design complexity of product, and the anticipated exposure to normal use.

Good practice dictates all Smirthwaite products have been designed and manufactured to high levels of safety and quality, and will meet requirements of normal use when maintained in line with our servicing recommendations.

**STOP!**

**If the product has been out of use for an extended period of time (6 months or more) it should always be serviced prior to being reissued.**

**If the product has been subjected to 'heavy' or 'constant' use, the service should be reduced to half the recommended period.**  
**Constant and/or heavy use is considered to be:**

- Daily use above 7 hours duration
- Weekly use above 5 days duration
- Monthly use above 10 months per year
- Use by a client who is at 90% to 100% of the maximum weight limit of the product. The maximum weight limit must **NEVER** be exceeded
- Use by a client who is extremely active, either voluntarily or involuntarily

## 5.4 EXTENDING NOMINAL SERVICE LIFE

At Smirthwaite we are proud to produce products that have a reputation for quality and durability.

We believe our products have the potential to provide benefits to our clients beyond the nominal service life documented above.

We will continue to provide full support beyond the nominal service life provided the following conditions are met:



1. A full service schedule has been maintained.
2. A full service and inspection is undertaken at the end of the nominal service life period.
3. The product is subsequently serviced annually (or biannually if under 'heavy/constant' use conditions).
4. Smirthwaite reserve the right to limit support where parts/components are no longer available.

## 5.5 DOCUMENTATION/RECORDS

- It is the responsibility of the current equipment owner to ensure the 'Instructions for Use' manual and any further manuals for accessories fitted to the equipment are handed over to the new owner at the time of exchange/sale.
- It is the responsibility of the current equipment owner to ensure the service and inspection record form is kept up to date.

## 5.6 PRODUCT CONFIGURATION

- Smirthwaite will document and maintain a record of the original product configuration at the time of first sale.
- Smirthwaite will not be held responsible for any subsequent changes to this configuration unless authorized to do so in writing by Smirthwaite Ltd.
- It is the equipment owner's responsibility to maintain their own records of changes to the equipment configuration and to be able to provide such records to subsequent owners to maintain traceability.
- We recommend an inspection/service by a Smirthwaite Service Engineer (or Smirthwaite trained engineer) whenever a significant change is made to product configuration to ensure the product is safe to use. **If in any doubt, ALWAYS seek ADVICE.**

	<b>IMPORTANT REMINDER!</b>
	<p><b>DO NOT</b> fit parts or accessories of other manufacturers to this product unless authorized to do so in writing by Smirthwaite Ltd.</p> <p>Any servicing or repairs required must be carried out by Smirthwaite Ltd (or a Smirthwaite trained engineer).</p> <p><b>If you believe this product to be faulty – DO NOT USE – Contact Smirthwaite Ltd on T: +44 (0) 1626 835552</b></p> <p><b>If in any doubt, ALWAYS seek ADVICE.</b></p>



## 6.0 WARRANTY & SERVICE

Smirthwaite Ltd warrants the products detailed on your order to be free from defects in materials and workmanship for a period of 2 years from date of delivery. If a fault develops during the period, please call Customer Services by email or telephone 01626 835552 who will advise you on the best course of action. Possible action may be for us to arrange to send out one of our Service Engineers, or have the goods returned to us. Should a repair not be possible within the guarantee period we will replace the product for new or nearest equivalent product. In the unlikely event that we cannot repair or exchange we will refund in full.

This warranty is for the UK only. The warranty excludes faults due to accident, neglect, misuse, not following the Instructions and normal wear and tear. This warranty is in addition to your legal rights. Goods will only be collected from the original delivery address.

A charge may be made where the goods cannot be repaired under the terms of the warranty. You will be advised before this is made.

T: +44 (0)1626 835552 E: [info@smirthwaite.co.uk](mailto:info@smirthwaite.co.uk)

**NO ADAPTATIONS OR ALTERATIONS SHOULD BE MADE TO THE FRAME WITHOUT WRITTEN AUTHORISATION BY SMIRTHWAITE - ANY SUCH MODIFICATION WILL AFFECT THE WARRANTY**

## 7.0 CONTINUOUS IMPROVEMENT

Smirthwaite Ltd are committed to continuous improvement to their product range. Should you have any suggestions or comments please send them to our product design department at: [info@smirthwaite.co.uk](mailto:info@smirthwaite.co.uk)

Smirthwaite Ltd reserve the right to change the specification or material without prior notice.

For catalogues, help and further information on our products please contact us at:

Smirthwaite Ltd  
16 Wentworth Road  
Heathfield  
Devon  
TQ12 6TL

T: +44 (0)1626 835552

E: [info@smirthwaite.co.uk](mailto:info@smirthwaite.co.uk) W: [www.smirthwaite.co.uk](http://www.smirthwaite.co.uk)



# 8.0 SERVICE INSPECTION

## 8.1 Product Information

Model:	
Size:	
Date of Manufacture:	
Serial Number:	
Final Inspection:	

## 8.2 Service & inspection record form:

Date	Procedure	Service Personnel



# 2. C Frame

---

## INSTRUCTIONS FOR USE

Code 44101



CONTENTS	PAGE
1.0 INTRODUCTION	15
2.0 ILLUSTRATION & TECHNICAL DATA	16
3.0 FOR YOUR SAFETY	17
4.0 ASSEMBLING YOUR C FRAME	18
5.0 CARE AND MAINTENENCE	7
6.0 WARRANTY AND SERVICE	10
7.0 CONTINUOUS IMPROVEMENT	10
8.0 SERVICE INSPECTION	11

---

## 1.0 INTRODUCTION

Thank you for choosing your new Smirthwaite 'C' Frame.

Our 'C' Frame is a free-standing suspension system for use with our sensory integration swing products. The frame eliminates the need for permanent structural fixings, is easy to transport and assemble. Made from tubular steel it will support rigorous activity and can be fixed to the floor if required.



### IMPORTANT!

**These instructions should be read by all therapists and carers using the equipment and should be retained for future reference. The product should always be used under adult supervision. This product is not a toy.**

**Any incorrect use of the product and failure to follow the instructions may put the user at risk or impede the function. If you have any queries using this product or wish for further copies, please do not hesitate to contact Customer Service department on T: +44 (0) 1626 835552.**

**This product has been designed and manufactured specifically and solely for use by clients with special needs.**





## 2.0 ILLUSTRATION OF YOUR 'C' FRAME

The 'C' Frame is supplied in parts, consisting of:

- 1 x single point head (A)
- 2 x vertical spines (B)
- 4 x legs (C)
- 3 x adjustable feet (D)
- 1 x shackle (E)
- 1 x cross brace bar (F)
- 1 x fixing kit

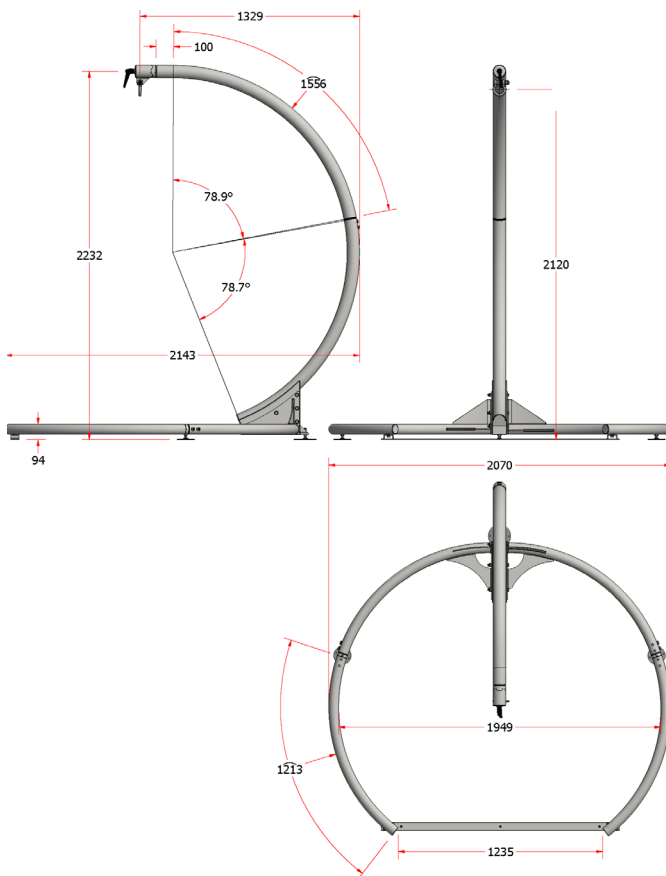
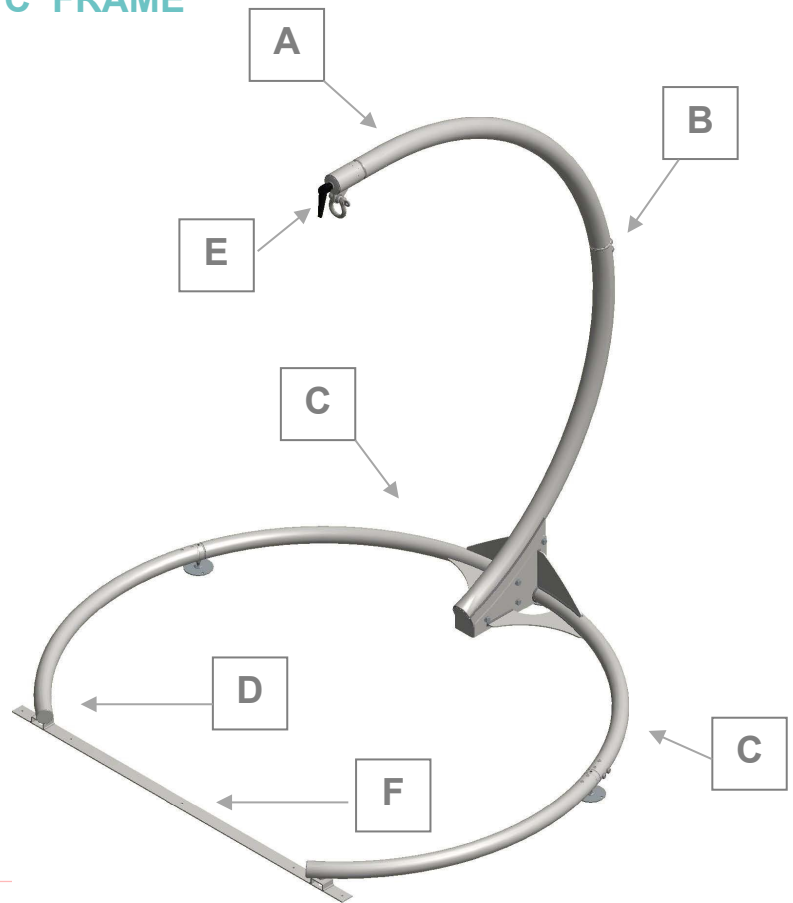

## 2.1 TECHNICAL DATA

Size	1	
<b>Product Code</b>		<b>44101</b>
Height	mm	2330
Footprint (diameter)	mm	1860
Maximum user weight	kg	150
Product weight	kg	120



### 3.0 FOR YOUR SAFETY



**STOP!**

**Please read these instructions CAREFULLY and THOROUGHLY**

- The user should NOT be left unattended whilst using the 'C' Frame. Always ensure a responsible adult or carer is in attendance. This product is not a toy.
- Regular maintenance checks and cleaning are essential for the safe use of this equipment (see care and maintenance section).
- Use only on a flat surface and do not exceed the weight limits specified.
- If any part is loose, damaged or functioning incorrectly, do not use until rectified.
- The 'C' Frame is supplied flat packed. Check before use that all parts are present and undamaged. Please refer to section 4.0 for assembly instructions.



**STOP!**

**If you believe this product to be faulty – DO NOT USE – Contact Smirthwaite Ltd on T: +44 (0) 1626 835552**



## 4.0 ASSEMBLING YOUR 'C' FRAME



### STOP!

If in any doubt, ALWAYS seek ADVICE

Always turn screws clockwise to tighten or anti-clockwise to loosen.

### 4.1 'C' FRAME – EXPLODED VIEW

- The 'C' frame is flat packed, consisting of 6 main tubular parts, 3 feet and a fixing set.
- The vertical spine can be self-supportive but it is always recommended a second person holds it steady whilst the legs are attached.

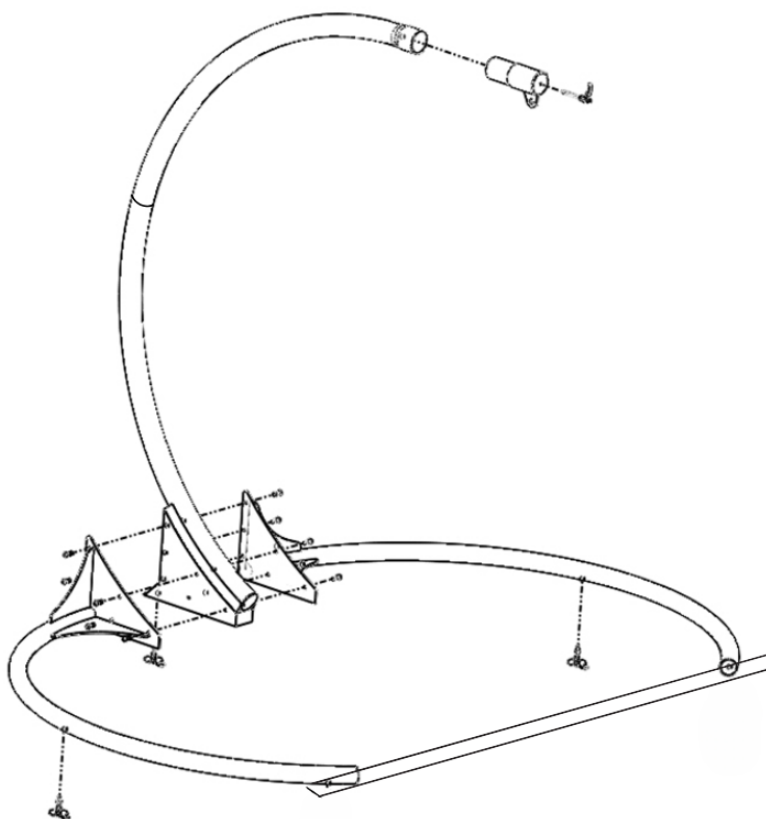

- Begin by connecting the two vertical spine components (E).
- Position the vertical spine (E) in an upright orientation; it should be largely self-supporting once vertical.
- Attach the first leg (F) and secure it in place using five M10 x 30mm bolts (G), as illustrated below.
- Repeat this process to secure the second leg to the vertical spine.

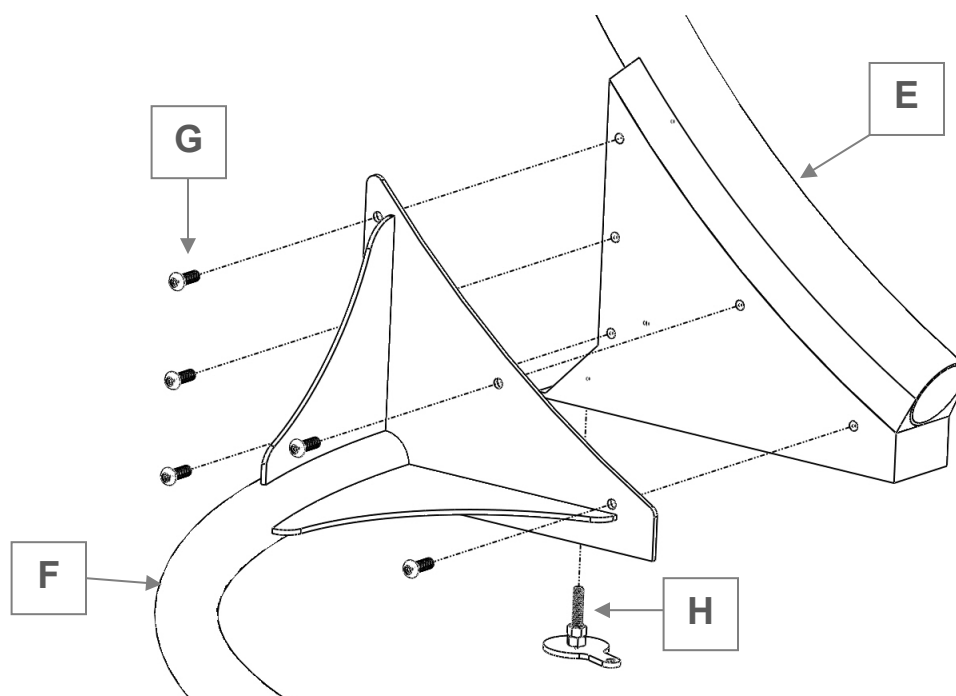

- To ensure stability, now insert the 3 feet (H). These are simply threaded into the underside of each leg (quantity 2) and the underside of the vertical spine (quantity).
- A lock nut is provided on each foot for adjustment in place when leveled.
- Each foot has an eye-hole feature through which a bolt can be positioned, allowing permanent fixing to the floor if required.
- Position the cross brace bar across the diameter of the frame, securing it to both vertical bases.

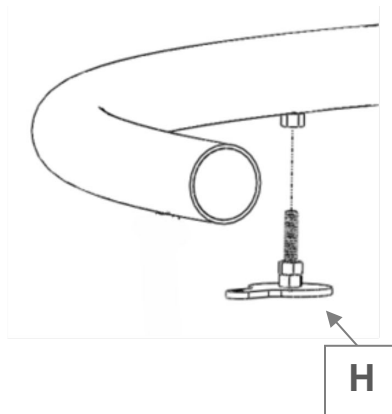

## 4.2 'C' FRAME – PADDING

- Before use, ensure the padding provided is fitted over the exposed metal parts of the 'C' frame.
- Simply wrap the neoprene padding onto the tube frame and zip to secure.
- The 'knuckle' of the frame is covered with the protection cover provided.

## 4.3 'C' FRAME – OPTIONAL MAT SET

- An optional mat set is available for the 'C' Frame.
- Supplied in 3 parts, the mats simply sit inside the footprint of the lower legs are secured together using the Velcro fasteners provided.

## 4.4 'C' FRAME – SINGLE AND TRIPLE POINT HEADS

- Slide the head (I) onto the end of the vertical spine as shown.
- Tighten the lever lock to secure in place.
- A triple point head accessory (product code 44201) is available – please contact the factory or your local product advisor for details.

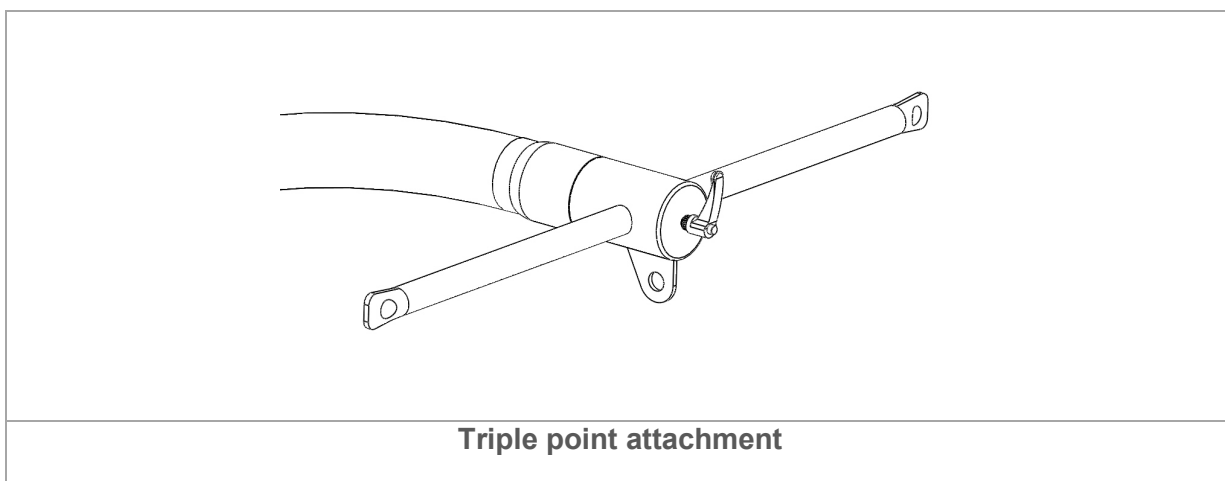
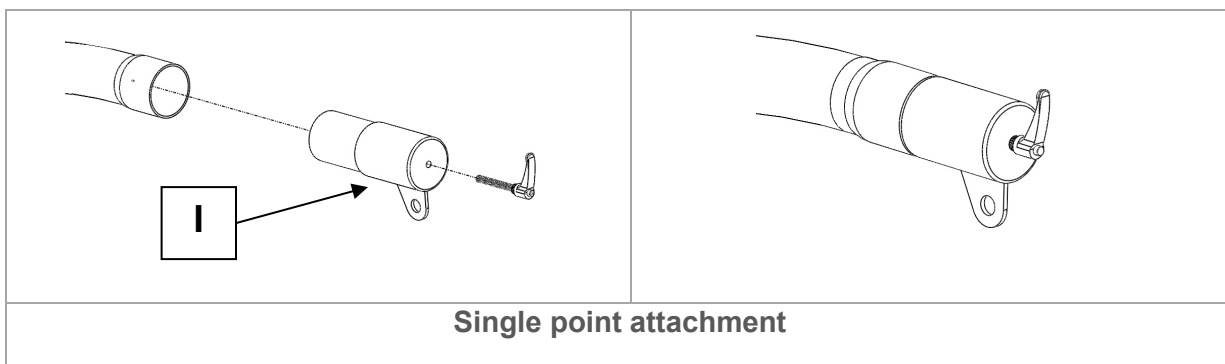

## 5.0 CARE AND MAINTENANCE



### IMPORTANT!

**Cleaning is recommended on a regular basis.**

- The 'C' frame padding can be cleaned with a damp cloth and mild detergent.
- The 'C' frame can be stored/positioned indoors or out.
- For further information please refer to MHRA or NHS cleaning guidelines.

### 5.1 DAILY CHECKS

- Check the frame for damage or loose connection points.
- Check all padding for signs of wear and tear.
- If the 'C' Frame is installed fixed to the ground, ensure the feet and fixing points are secure.
- Keep all parts clean.



### STOP!

**DO NOT attempt to use the product while being checked or serviced.**

### 5.2 SERVICE INTERVAL

The 'C' Frame should be serviced every year. Servicing must only be undertaken by a Smirthwaite service engineer, or by a Smirthwaite trained representative.

### 5.3 NOMINAL SERVICE LIFE

Your product has a nominal service life of 7 years, during which full post-sales support will be available with regard to spares and servicing.

Product service life has been determined based upon the design complexity of product, and the anticipated exposure to normal use.

Good practice dictates all Smirthwaite products have been designed and manufactured to high levels of safety and quality and will meet requirements of normal use when maintained in line with our servicing recommendations.





## STOP!

If the product has been out of use for an extended period of time (6 months or more) it should always be serviced prior to being reissued.

If the product has been subjected to 'heavy' or 'constant' use, the service should be reduced to half the recommended period.

Constant and/or heavy use is considered to be:

- Daily use above 7 hours duration
- Weekly use above 5 days duration
- Monthly use above 10 months per year
- Use by a client who is at 90% to 100% of the maximum weight limit of the product. The maximum weight limit must **NEVER** be exceeded
- Use by a client who is extremely active, either voluntarily or involuntarily.

## 5.4 EXTENDING NOMINAL SERVICE LIFE

At Smirthwaite we are proud to produce products that have a reputation for quality and durability.

We believe our products have the potential to provide benefits to our clients beyond the nominal service life documented above.

We will continue to provide full support beyond the nominal service life provided the following conditions are met:

5. A full service schedule has been maintained.
6. A full service and inspection is undertaken at the end of the nominal service life period.
7. The product is subsequently serviced annually (or biannually if under 'heavy/constant' use conditions).
8. Smirthwaite reserve the right to limit support where parts/components are no longer available.

## 5.5 DOCUMENTATION/RECORDS

- It is the responsibility of the current equipment owner to ensure the 'Instructions for Use' manual and any further manuals for accessories fitted to the equipment are handed over to the new owner at the time of exchange/sale.
- It is the responsibility of the current equipment owner to ensure the service and inspection record form is kept up to date.



## 5.6 PRODUCT CONFIGURATION

- Smirthwaite will document and maintain a record of the original product configuration at the time of first sale.
- Smirthwaite will not be held responsible for any subsequent changes to this configuration unless authorized to do so in writing by Smirthwaite Ltd.
- It is the equipment owner's responsibility to maintain their own records of changes to the equipment configuration and to be able to provide such records to subsequent owners to maintain traceability.
- We recommend an inspection/service by a Smirthwaite Service Engineer (or Smirthwaite trained engineer) whenever a significant change is made to product configuration to ensure the product is safe to use. **If in any doubt, ALWAYS seek ADVICE.**



### IMPORTANT REMINDER!

**DO NOT** fit parts or accessories of other manufacturers to this product unless authorized to do so in writing by Smirthwaite Ltd.

Any servicing or repairs required must be carried out by Smirthwaite Ltd (or a Smirthwaite trained engineer).

**If you believe this product to be faulty – DO NOT USE – Contact Smirthwaite Ltd on T: +44 (0) 1626 835552  
If in any doubt, ALWAYS seek ADVICE.**

## 6.0 WARRANTY & SERVICE

Smirthwaite Ltd warrants the products detailed on your order to be free from defects in materials and workmanship for a period of 2 years from date of delivery. If a fault develops during the period, please call Customer Services by email or telephone 01626 835552 who will advise you on the best course of action. Possible action may be for us to arrange to send out one of our Service Engineers, or have the goods returned to us. Should a repair not be possible within the guarantee period we will replace the product for new or nearest equivalent product. In the unlikely event that we cannot repair or exchange we will refund in full. This warranty is for the UK only. The warranty excludes faults due to accident, neglect, misuse, not following the Instructions and normal wear and tear. This warranty is in addition to your legal rights. Goods will only be collected from the original delivery address.

A charge may be made where the goods cannot be repaired under the terms of the warranty. You will be advised before this is made.

**NO ADAPTATIONS OR ALTERATIONS SHOULD BE MADE TO THE FRAME WITHOUT WRITTEN AUTHORISATION BY SMIRTHWAITE - ANY SUCH MODIFICATION WILL AFFECT THE WARRANTY.**





## 7.0 CONTINUOUS IMPROVEMENT

Smirthwaite Ltd are committed to continuous improvement to their product range. Should you have any suggestions or comments please send them to our product design department at: [info@smirthwaite.co.uk](mailto:info@smirthwaite.co.uk)

Smirthwaite Ltd reserve the right to change the specification or material without prior notice.

For catalogues, help and further information on our products please contact us at:

Smirthwaite Ltd  
16 Wentworth Road  
Heathfield  
Devon  
TQ12 6TL

T: +44 (0)1626 835552  
E: [info@smirthwaite.co.uk](mailto:info@smirthwaite.co.uk)  
W: [www.smirthwaite.co.uk](http://www.smirthwaite.co.uk)

## 8.0 SERVICE INSPECTION

### 8.1 Product Information

Model	
Size	
Date of Manufacture	
Serial Number	
Final Inspection	

### 8.2 Service & inspection record form:

Date	Procedure	Service Personnel



# 3. O Frame

## INSTRUCTIONS FOR USE

Code 44501



<b>CONTENTS</b>	<b>PAGE</b>
1.0 INTRODUCTION	1
2.0 ILLUSTRATION OF YOUR O FRAME	2
3.0 FOR YOUR SAFETY	3
4.0 ASSEMBLING YOUR O FRAME	4
5.0 CARE AND MAINTENENCE	7
6.0 WARRANTY AND SERVICE	10
7.0 CONTINUOUS IMPROVEMENT	10
8.0 SERVICE WARRANTY	11

---

## 1.0 INTRODUCTION

Thank you for choosing your new Smirthwaite 'O' Frame.

Our 'O' Frame is a free-standing suspension system for use with our sensory integration swing products. The frame eliminates the need for permanent structural fixings, is easy to transport and assemble. Made from tubular steel it will support rigorous activity and can be fixed to the floor if required.



### **IMPORTANT!**

**These instructions should be read by all therapists and carers using the equipment and should be retained for future reference. The product should always be used under adult supervision – this product is not a toy.**

**Any incorrect use of the product and failure to follow the instructions may put the user at risk or impede the function. If you have any queries using this product or wish for further copies, please do not hesitate to contact Customer Service department on  
T: +44 (0) 1626 835552.**

**This product has been designed and manufactured specifically and solely for use by clients with special needs.**



## 2.0 ILLUSTRATION OF YOUR O FRAME

The O Frame is supplied in parts, consisting of:

- 3 x fixing points (A)
- 4 x vertical spine (B)
- 2 x horizontal frame (C)
- 3 x shackles (D)
- 6 x adjustable feet (E)
- 1 x fixing kit

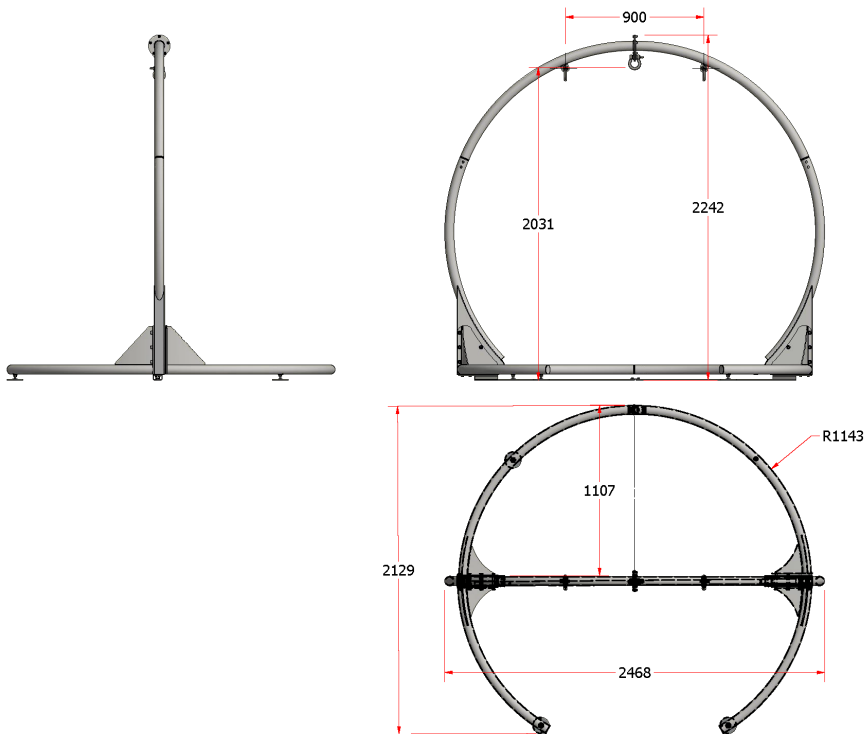
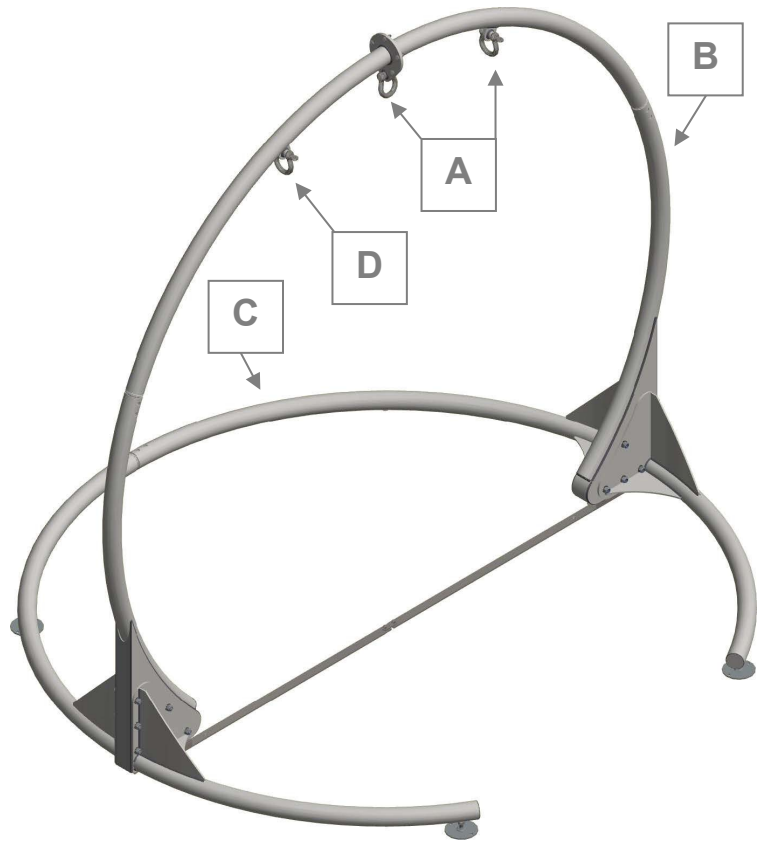

## 2.1 TECHNICAL DATA

Size		1
Product Code		44501
Height	mm	2200
Footprint (diameter)	mm	2350
Maximum user weight	kg	300
Product weight	kg	120

## 3.0 FOR YOUR SAFETY

	<b>STOP!</b>
	<b>Please read these instructions CAREFULLY and THOROUGHLY</b>

- The user should NOT be left unattended whilst using the 'O' Frame. Always ensure a responsible adult or carer is in attendance – this product is not a toy
- Regular maintenance checks and cleaning are essential for the safe use of this equipment (see care and maintenance section).
- Use only on a flat surface and do not exceed the weight limits specified.
- If any part is loose, damaged or functioning incorrectly, do not use until rectified.
- The 'O' Frame is supplied flat packed. Check before use that all parts are present and undamaged. Please refer to section 4.0 for assembly instructions.

	<b>STOP!</b>
	<b>If you believe this product to be faulty – DO NOT USE – Contact Smirthwaite Ltd on T: +44 (0) 1626 835552</b>



## 4.0 ASSEMBLING YOUR 'O' FRAME



**STOP!**

If in any doubt, **ALWAYS** seek **ADVICE**

**Always turn screws clockwise to tighten or anti-clockwise to loosen.**

### 4.1 'O' FRAME – EXPLODED VIEW

- The 'O' frame is flat packed, consisting of 8 main tubular parts, 6 adjustable feet and a fixing set.
- It is possible for one person to assemble the frame safely, though if you are in any doubt, seek assistance.

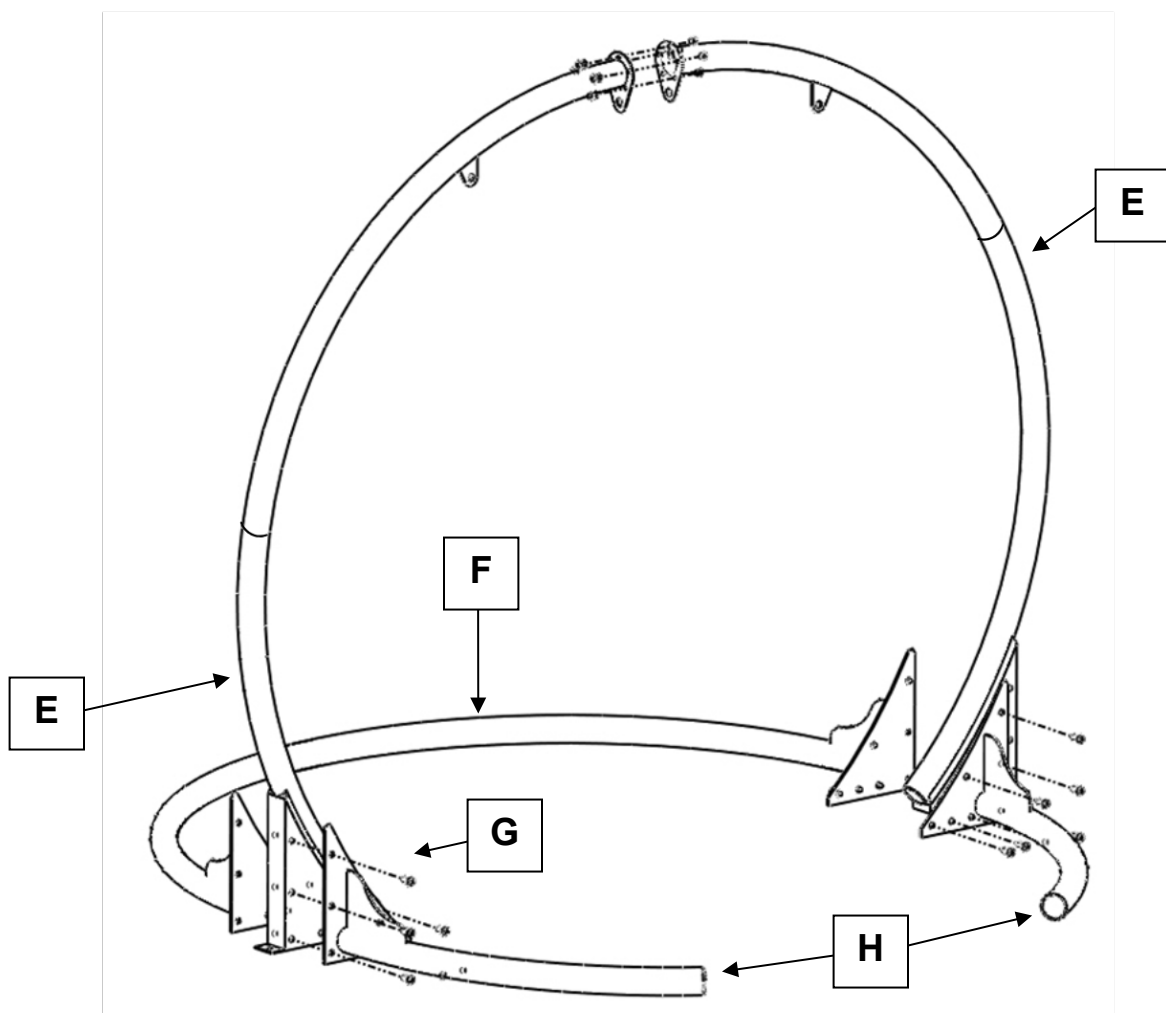

- Begin by connecting the four vertical spine components; two components each side (E).
- Position the two vertical spines (E) upright - they should be self-supporting once vertical.
- Align the two vertical spines together at their top interface, and secure using the 6 x M10 X 25mm bolts and nuts provided (see below).

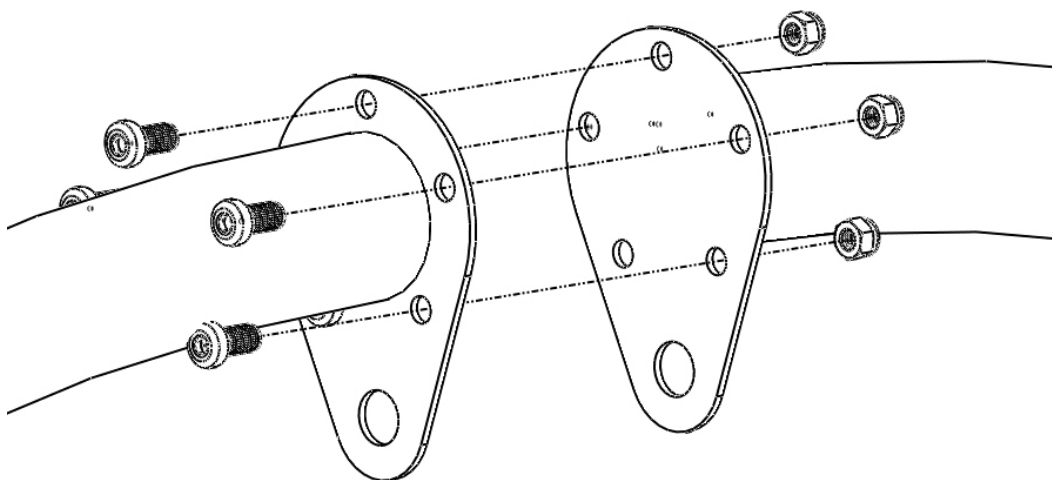

- Offer up the main horizontal leg (F) and secure in place using 14 x M10 x 25mm bolts (G) as shown.
- Offer up the two stub horizontal legs (H) and secure into place using 14 x M10 x 25mm bolts (G) as shown.
- If required to stabilize, insert the 6 feet (I). These are simply threaded into the underside of each leg (quantity 2) and the underside of the vertical spine.
- A lock nut is provided on each foot for adjustment in place when leveled.
- Each foot has an eye-hole feature through which a bolt can be positioned, allowing permanent fixing to the floor if required.
- Position the cross brace bar across the diameter of the frame, securing it to both vertical bases.

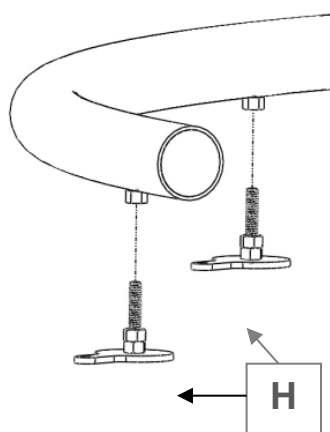

## 4.2 'O' FRAME – PADDING

- Before use, ensure the padding provided is fitted over the exposed metal parts of the 'O' frame.
- Simply wrap the neoprene padding onto the tube frame and zip to secure.
- The 'knuckle' of each vertical spine is covered with the protection box provided.

## 5.0 CARE AND MAINTENANCE

	<b>IMPORTANT!</b>
	<b>Cleaning is recommended on a regular basis</b>

- The 'O' frame padding can be cleaned with a damp cloth and mild detergent.
- The 'O' frame can be stored/positioned indoors or out.
- For further information please refer to MHRA or NHS cleaning guidelines.

### 5.1 DAILY CHECKS

- Check the frame for damage or loose connection points.
- Check all padding for signs of wear and tear.
- If the 'O' Frame is installed fixed to the ground, ensure the feet and fixing points are secure.
- Keep all parts clean.

	<b>STOP!</b>
	<b>DO NOT attempt to use the product while being checked or serviced.</b>

### 5.2 SERVICE INTERVAL

The 'O' Frame should be serviced every year. Servicing must only be undertaken by a Smirthwaite service engineer, or by a Smirthwaite trained representative.

### 5.3 NOMINAL SERVICE LIFE

Your product has a nominal service life of 7 years, during which full post-sales support will be available with regard to spares and servicing.

Product service life has been determined based upon the design complexity of product, and the anticipated exposure to normal use.





Good practice dictates all Smirthwaite products have been designed and manufactured to high levels of safety and quality, and will meet requirements of normal use when maintained in line with our servicing recommendations.

	<b>STOP!</b>
	<p><b>If the product has been out of use for an extended period of time (6 months or more) it should always be serviced prior to being reissued.</b></p> <p><b>If the product has been subjected to 'heavy' or 'constant' use, the service should be reduced to half the recommended period. Constant and/or heavy use is considered to be:</b></p> <ul style="list-style-type: none"><li>• Daily use above 7 hours duration</li><li>• Weekly use above 5 days duration</li><li>• Monthly use above 10 months per year</li><li>• Use by a client who is at 90% to 100% of the maximum weight limit of the product. The maximum weight limit must <b>NEVER</b> be exceeded</li><li>• Use by a client who is extremely active, either voluntarily or involuntarily</li></ul>

## 5.4 EXTENDING NOMINAL SERVICE LIFE

At Smirthwaite we are proud to produce products that have a reputation for quality and durability.

We believe our products have the potential to provide benefits to our clients beyond the nominal service life documented above.

We will continue to provide full support beyond the nominal service life provided the following conditions are met:

9. A full service schedule has been maintained.
10. A full service and inspection is undertaken at the end of the nominal service life period.
11. The product is subsequently serviced annually (or biannually if under 'heavy/constant' use conditions).
12. Smirthwaite reserve the right to limit support where parts/components are no longer available.



## 5.5 DOCUMENTATION/RECORDS

- It is the responsibility of the current equipment owner to ensure the 'Instructions for Use' manual and any further manuals for accessories fitted to the equipment are handed over to the new owner at the time of exchange/sale.
- It is the responsibility of the current equipment owner to ensure the service and inspection record form is kept up to date.

## 5.6 PRODUCT CONFIGURATION

- Smirthwaite will document and maintain a record of the original product configuration at the time of first sale.
- Smirthwaite will not be held responsible for any subsequent changes to this configuration unless authorized to do so in writing by Smirthwaite Ltd.
- It is the equipment owner's responsibility to maintain their own records of changes to the equipment configuration and to be able to provide such records to subsequent owners to maintain traceability.
- We recommend an inspection/service by a Smirthwaite Service Engineer (or Smirthwaite trained engineer) whenever a significant change is made to product configuration to ensure the product is safe to use. **If in any doubt, ALWAYS seek ADVICE.**



### IMPORTANT REMINDER!

**DO NOT** fit parts or accessories of other manufacturers to this product unless authorized to do so in writing by Smirthwaite Ltd.

Any servicing or repairs required must be carried out by Smirthwaite Ltd (or a Smirthwaite trained engineer).

**If you believe this product to be faulty – DO NOT USE – Contact Smirthwaite Ltd on T: +44 (0) 1626 835552**

**If in any doubt, ALWAYS seek ADVICE.**



## 6.0 WARRANTY & SERVICE

Smirthwaite Ltd warrants the products detailed on your order to be free from defects in materials and workmanship for a period of 2 years from date of delivery. If a fault develops during the period, please call Customer Services by email or telephone 01626 835552 who will advise you on the best course of action. Possible action may be for us to arrange to send out one of our Service Engineers, or have the goods returned to us. Should a repair not be possible within the guarantee period we will replace the product for new or nearest equivalent product. In the unlikely event that we cannot repair or exchange we will refund in full.

This warranty is for the UK only. The warranty excludes faults due to accident, neglect, misuse, not following the Instructions and normal wear and tear. This warranty is in addition to your legal rights. Goods will only be collected from the original delivery address.

A charge may be made where the goods cannot be repaired under the terms of the warranty. You will be advised before this is made.

T: +44 (0)1626 835552 E: [info@smirthwaite.co.uk](mailto:info@smirthwaite.co.uk)

**NO ADAPTATIONS OR ALTERATIONS SHOULD BE MADE TO THE FRAME WITHOUT WRITTEN AUTHORISATION BY SMIRTHWAITE - ANY SUCH MODIFICATION WILL AFFECT THE WARRANTY**

## 7.0 CONTINUOUS IMPROVEMENT

Smirthwaite Ltd are committed to continuous improvement to their product range.

Should you have any suggestions or comments please send them to our product design department at: [info@smirthwaite.co.uk](mailto:info@smirthwaite.co.uk)

Smirthwaite Ltd reserve the right to change the specification or material without prior notice.

For catalogues, help and further information on our products please contact us at:

Smirthwaite Ltd  
16 Wentworth Road  
Heathfield  
Devon  
TQ12 6TL

T: +44 (0)1626 835552  
E: [info@smirthwaite.co.uk](mailto:info@smirthwaite.co.uk)  
W: [www.smirthwaite.co.uk](http://www.smirthwaite.co.uk)



## 8.0 SERVICE INSPECTION

### 8.1 Product Information

Model	
Size	
Date of Manufacture	
Serial Number	
Final Inspection	

### 8.2 Service & inspection record form:

Date	Procedure	Service Personnel



Smirthwaite, 16 Wentworth Road, Heathfield, Newton Abbot, Devon.TQ12 6TL  
T: +44 (0) 1626 835552 E: [info@smirthwaite.co.uk](mailto:info@smirthwaite.co.uk) [www.smirthwaite.co.uk](http://www.smirthwaite.co.uk)

